

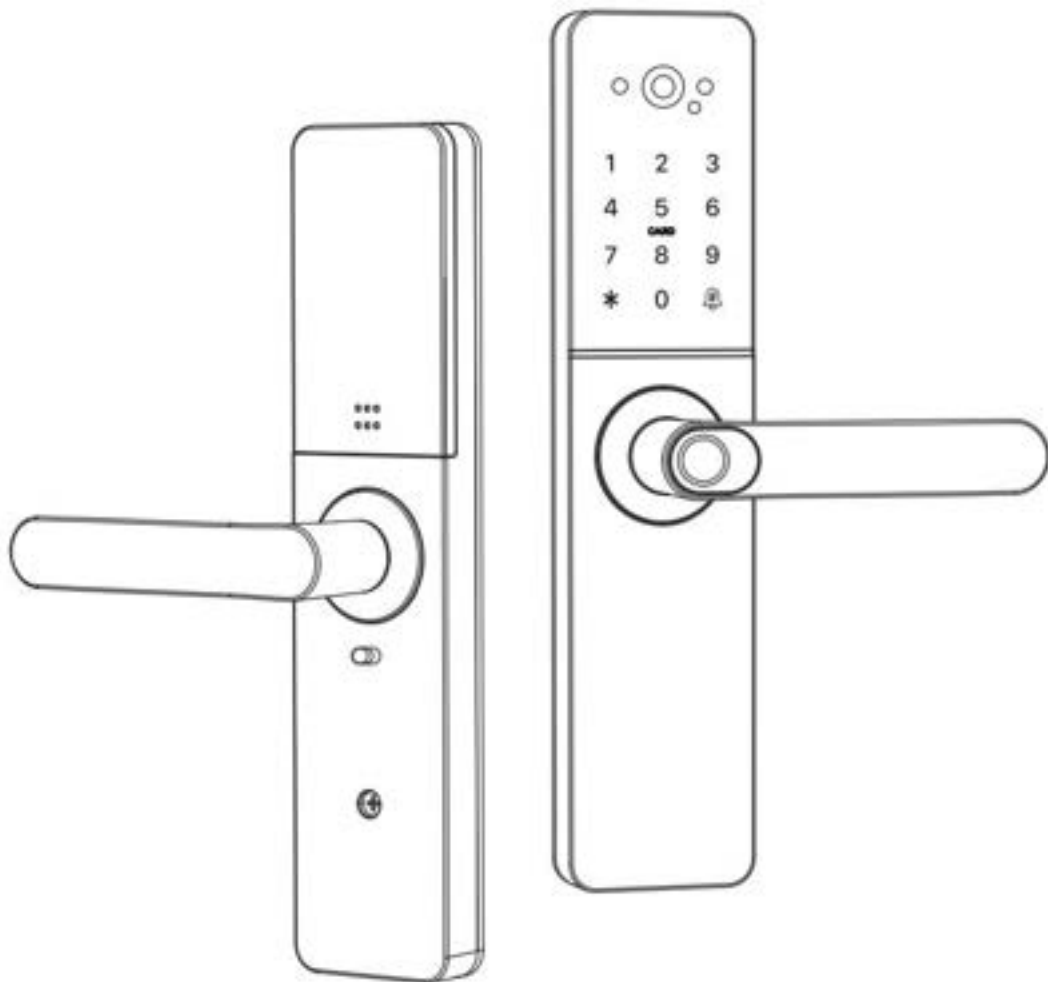

Smart Lock

User Manual

H91B-TWM



Special Attention:

1. Please keep the keys outside the door in case of emergency.
2. Please replace the battery when low battery is indicated.
3. Read this user manual carefully before installation.



1. Introduction

1.1. Lock structure

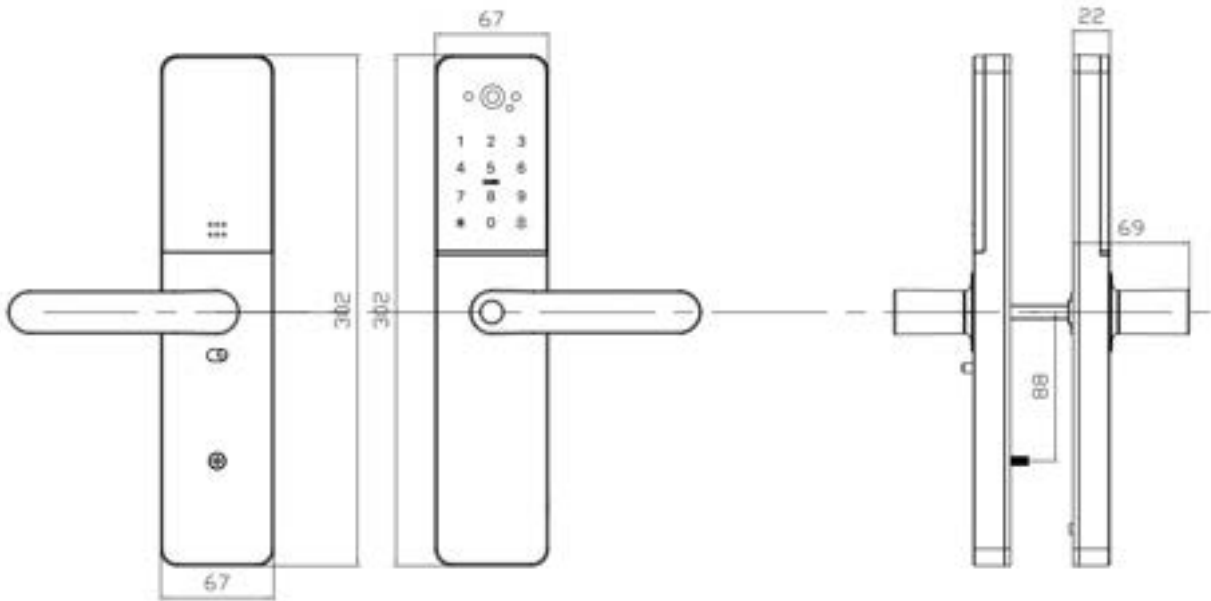

1.2. Packing List

💡 Check the following list which contains all the parts.

NO	Name	Qty	NO.	Name	Qty
1	Front Panel	1	11	Screws: M5*10mm (For Aluminium Door)	4
2	Back Panel	1	12	Screws: M5*20mm (For Wooden Door)	5
3	Mortise Lock Body	1	13	60mm Square shaft	1
4	IC Card	3	14	80mm Square shaft	1
5	Keys	2	15	M5*25mm Screw	1
6	Waterproof Rubber Seal	2	16	M5*40mm Screw	1
7	Connecting Posts: M5*30mm	2	17	M5*50mm Screw	1
8	Connecting Posts: M5*40mm	2	18	M5*11mm Sliding screw (screw into connecting posts)	1
9	Striker Plate & Strike Box	1+1	19	Split pin	1
10	User Manual	1			



1.3. Specifications

Model Number	H91B-TWM	Doors Applicable	Aluminium door Wooden door
Materials	Panel: ADC12 Handle: ADC12	Working Voltage	Lithium battery
Lock Weight	3KG	Door Thickness to Fit	35-60mm
Unlocking Way	Bluetooth Fingerprint Passcode IC Card Keys Gateway(option)	Data Capacity	Fingerprint: 200 Passcode: 150 IC Card: 200
Colour	Silver Black	Working Temperature	-10°C - 55°C
Low Wattage Alarm	Less than 7.2V	Working Humidity	0-95%

1.4. Factory Reset

Open the cover plate of the back panel, push down the "Reset" button on the back above the batteries for about 5 seconds until voice instructs to input "000 #", then the lock will reset back to its original state after the buzzer beeps twice.

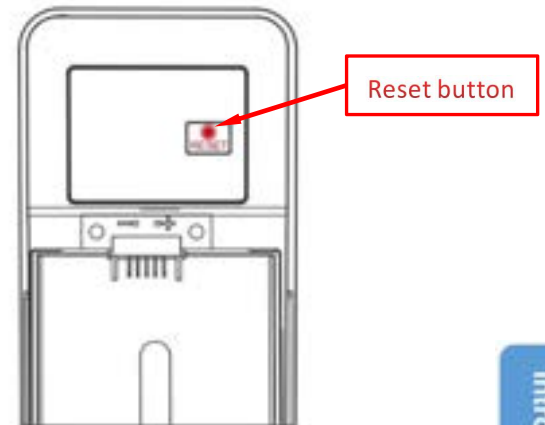

1.5. Privacy Locking Switch

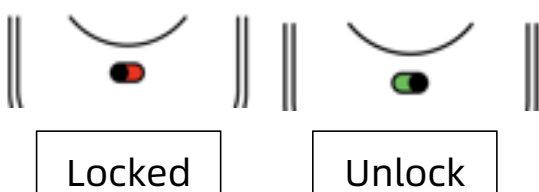

1. If you want to have the "privacy locking switch" working, first turn on "privacy lock" on the app.
2. When the button is in the red position, it is in the locked state and can only be unlocked through the administrator app or key.



2. Installation

2.1 Adjusting the handle

Adjust the handle according to the direction you open the door.

For Front Panel



1. Loosen screw

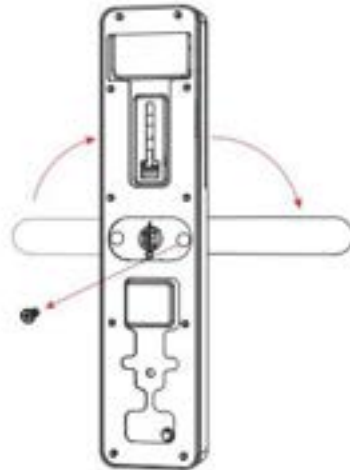

2. Flip over to other side to suit your door if needed.

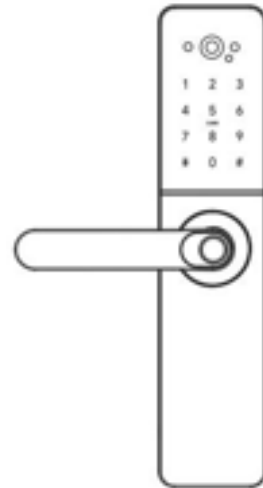

3. Tighten back the screw on the opposite side of the shaft after adjusting the direction.



For Back Panel

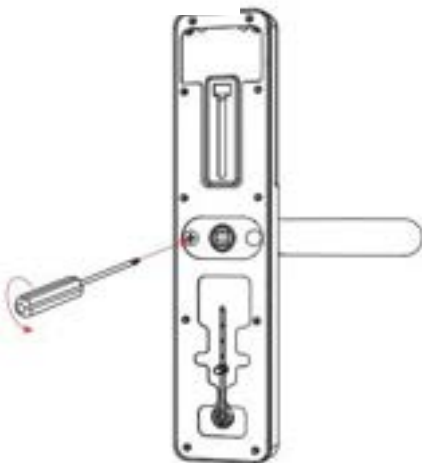

1. Loosen screw

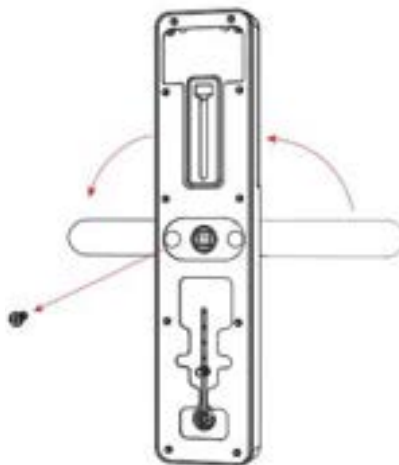

2. Flip over to other side to suit your door if needed.

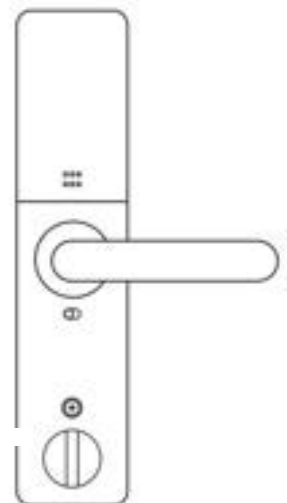

3. Tighten back the screw on the opposite side of the shaft after adjusting the direction.



2.2. Installation Diagram

Step 1 Install Mortise Lock Body

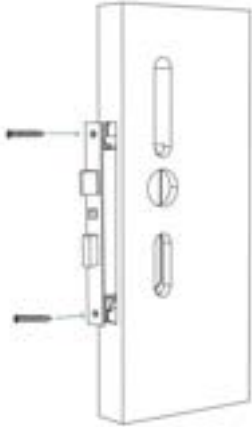

Install the mortise lock body into the door with screws.

Step 2 Install Front Panel

1. Install the waterproof rubber seal to front panel.
2. Install square shaft into spindle hub, keep the arrow on the hub pointing down.
3. Install two connecting posts onto the front panel.

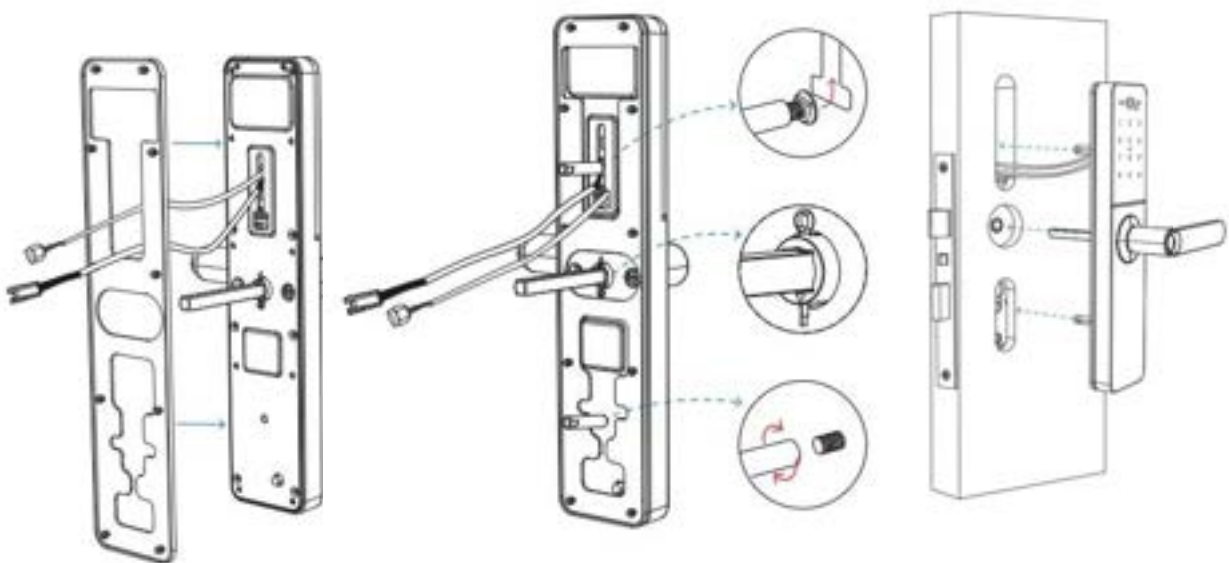



Step 3 Install Back Panel

1. Install the waterproof rubber seal.
2. Open the battery cover .
3. Connect the wires.

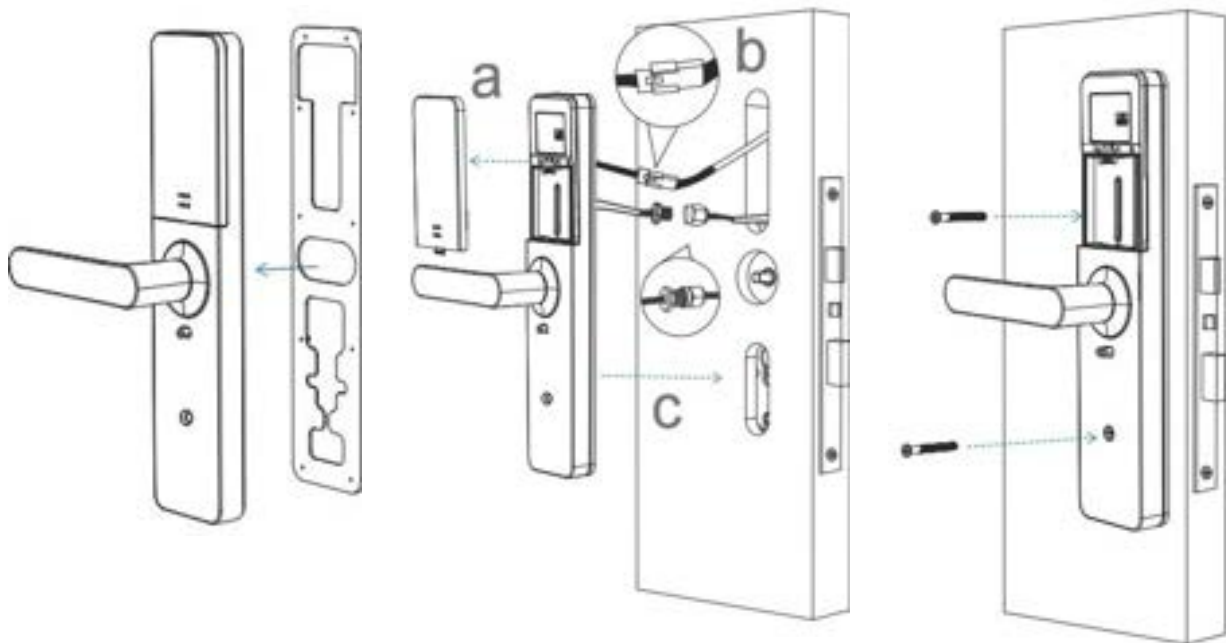

Step 4 Install batteries

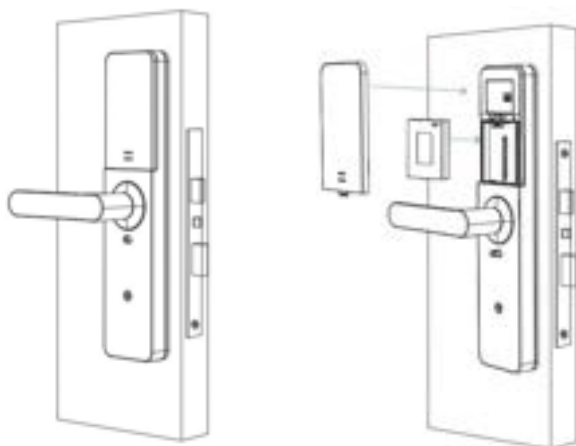

1. Install rechargeable lithium battery.
2. Place back the battery cover.
3. Installation complete .



3. Operation

3.1. Registration

Download and install “TTLock” from your App Store or Google Play. Scan the appropriate QR Code to get started. Open TTLock and tap the Register button to create a new TTLock account using either your phone number or email address. If you already have a TTLock account then simply login.

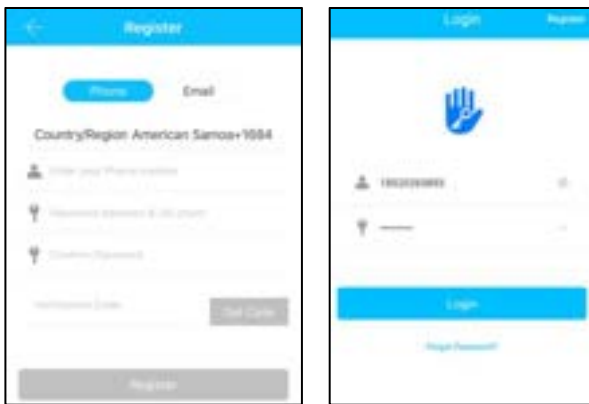

TTlock users can register the account by mobile phone and Email which currently support 200 countries and regions on the world. The verification code will be sent to user’s mobile phone or email, and the registration will be successful after the verification.

3.2. Connect lock to the phone

- 1) Be sure that Bluetooth is enabled on your phone and that you are within a few feet of your smart lock.
- 2) Touch the key pad to light up the lock screen, select "+ Add Lock" in TTLock. then select "All Lock" from the "Choose Lock Type" screen.
- 3) Select the "+" button next to your lock when it appears in the list. Your lock will then say "Adding administrator successful". You are now the Bluetooth administrator of the lock.
- 4) Next you will be prompted to assign a name to your lock.
- 5) Re-name the lock.
- 6). Then your lock has successfully been added.



3.3.Add more locks

TTLock supports multiple types of lock devices. The lock needs to be added by the app after entering the add mode. Generally, a lock that has not been added, as long as the lock keyboard is touched, it will enter the add mode. The default password is 123456 if not added by the phone.

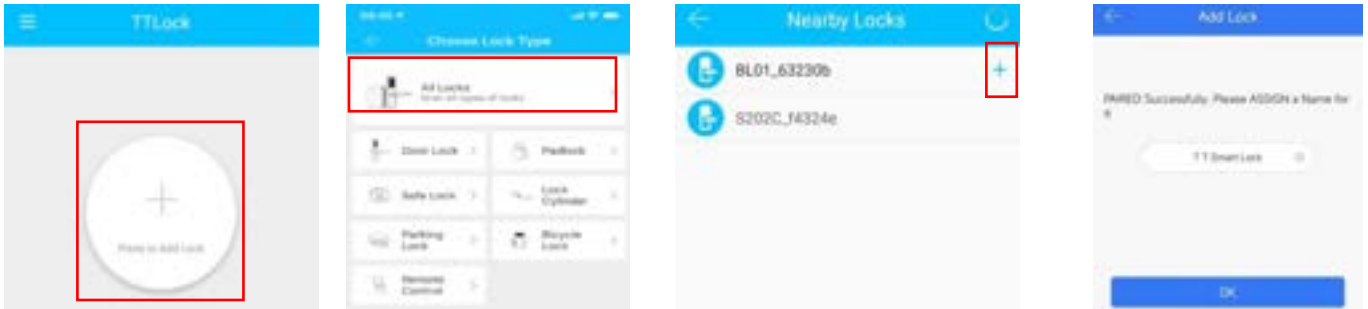

3.4.Connect WiFi

Click on the "Settings" as shown in figure 1, you can set up the WiFi setting → Select "WiFi" → Click on the "Configure network", chose the 2.4Gz WiFi what you need. (If you need to change your WiFi, this step will help you.)

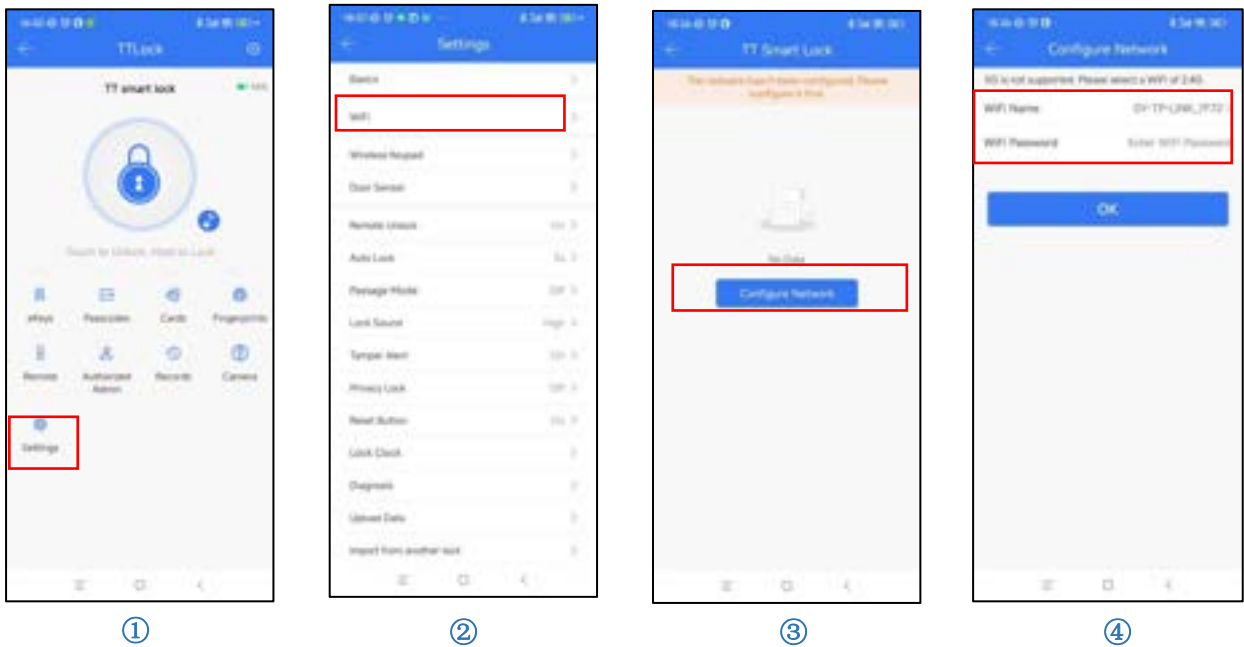

①

②

③

④



3.5. Power saving mode

a) Turn off the "Power saving mode"

Keep WiFi connected at all times, You can use the app to remotely unlock and turn on the camera for visual intercom.

b) Turn on the "Power saving mode"

Unable to unlock through "🔑" and unable to actively wake up the camera, the reported message can be received.

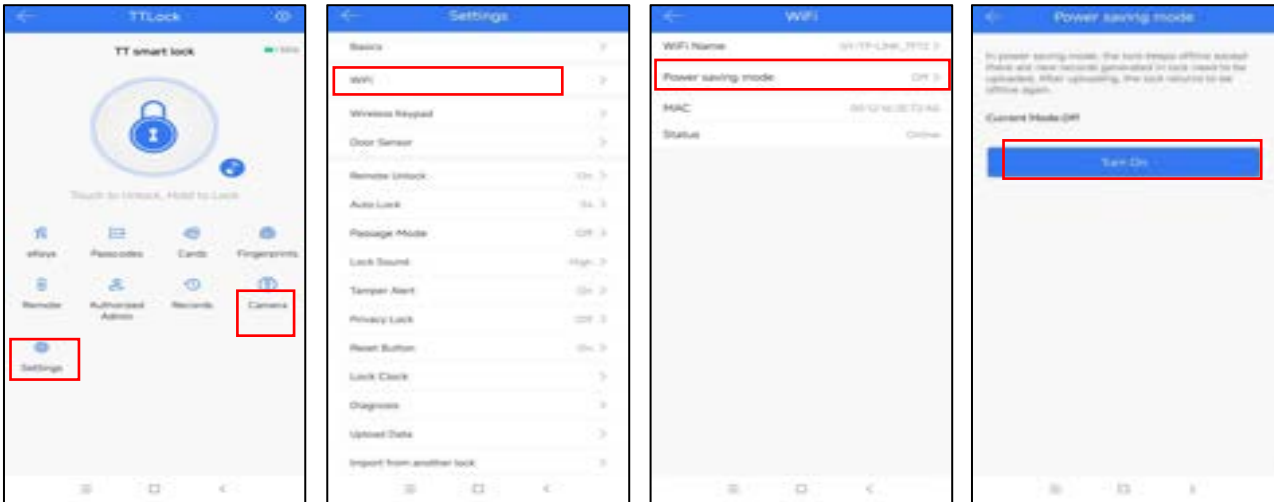

3.6. User Management

3.6.1. Bluetooth management

Make sure there is no problem with Bluetooth communication. After connecting the phone to the door lock as above, Click "🔑" to unlock. (the phone should be within 5 meters from the door lock).

3.6.2. Setting Passcode

Passcodes are also a way to unlock. After entering the passcode on the locked keyboard, then press the unlock button "#" in the lower right corner to unlock. Passcodes are divided into permanent, timed, one-time, custom, recurring, and erase. (You can share the Passcode to other users via SMS, Email, Messenger, Whatsapp).

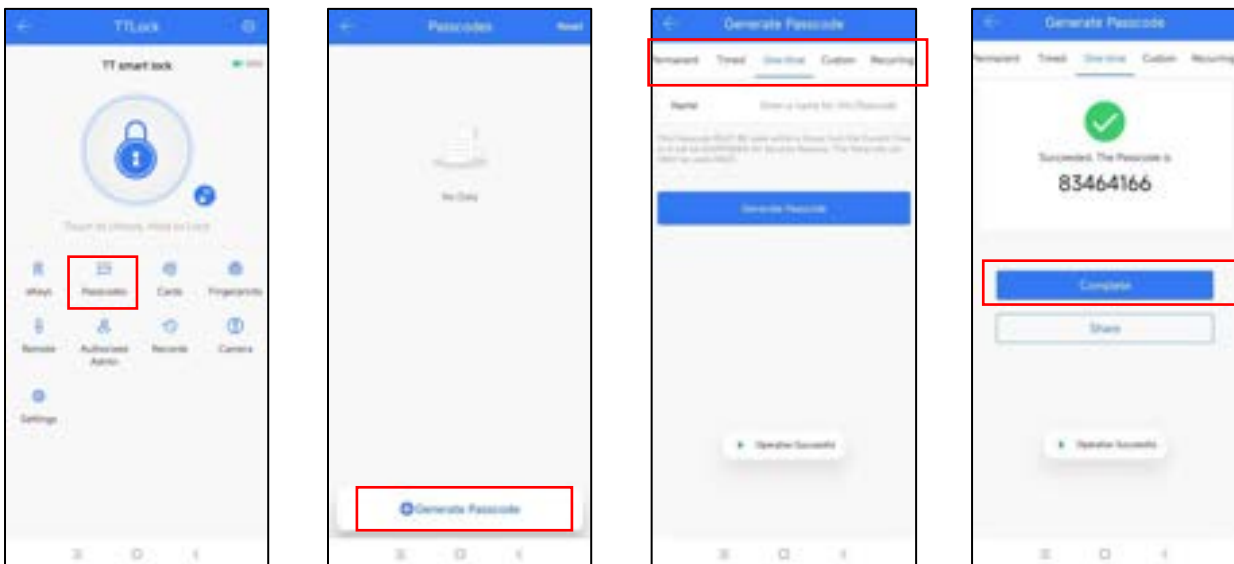



3.6.3. Send e-Key



Click on the " Send eKey " as shown in figure, you can send the eKey to other users of TTlock to authorize the unlock (the receiver must also download the APP and set up an account)→ Select e-key format (Timed, permanent, One-time, Recurring) → Enter recipient's account of TTlock, set the name and effective time of the eKey, Can choose to allow remote unlocking, camera permission or disallowing, authorized administrator or not authorized, as shown in figure → Send → The recipient's account has Bluetooth unlock permission.

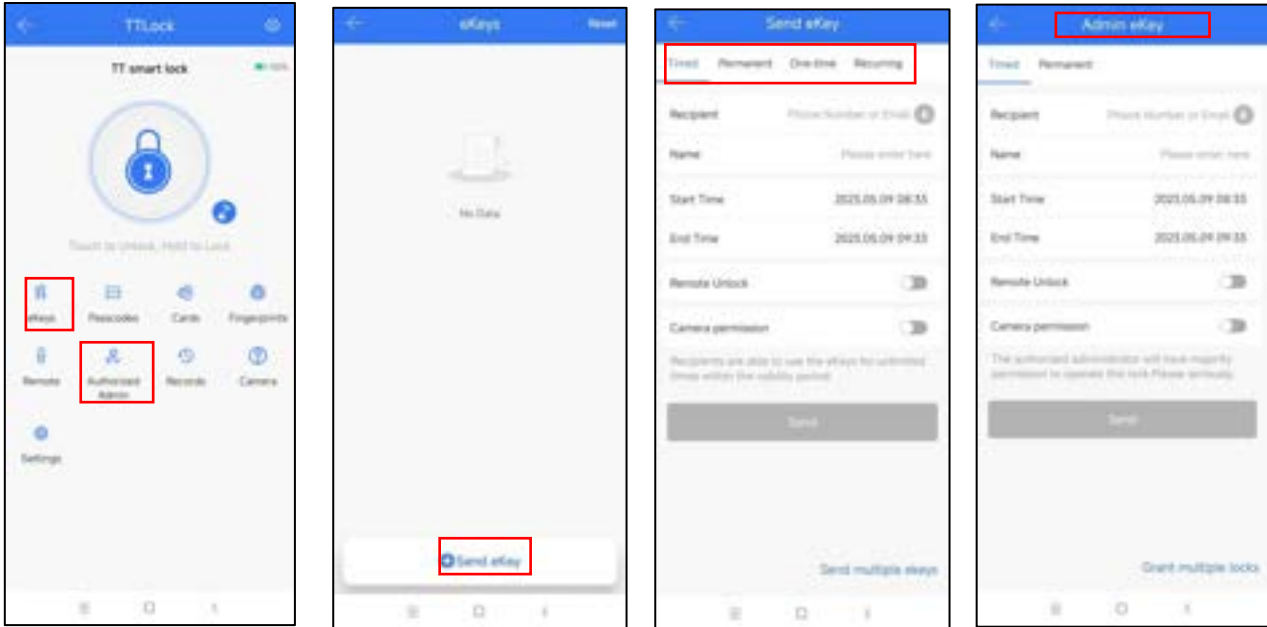



3.6.4.Add card

Supports opening doors through the IC card supplied. Before an IC card is used to open the door, it needs to be added first. The adding process needs to be performed by the app beside the lock. The validity period of the IC can be set, it can be permanent, timed or recurring.

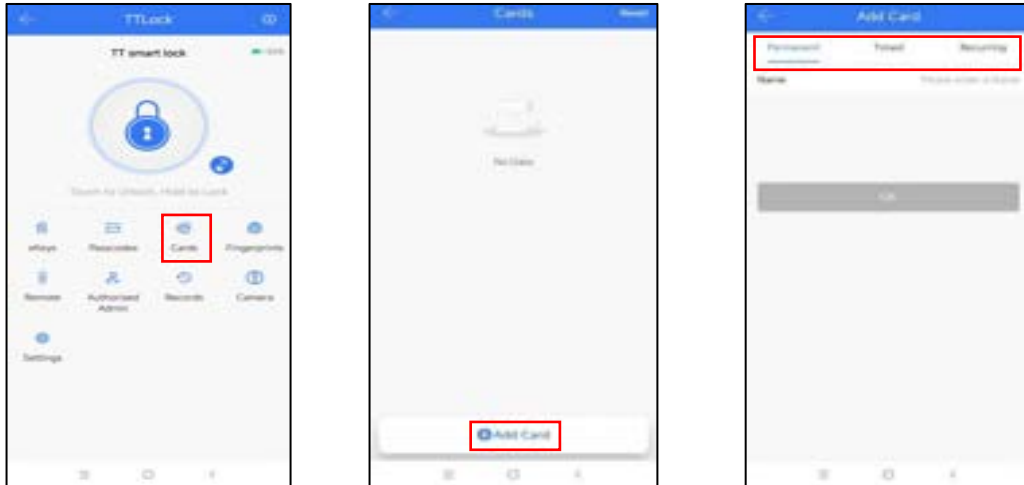

3.6.5.Add fingerprint

The premise that a fingerprint can be used to open a door is that it needs to be added first. The adding process needs to be performed by the APP beside the lock. The fingerprint expiration data can be set, it can be permanent, timed or recurring. After setting , you can modify its validity period.

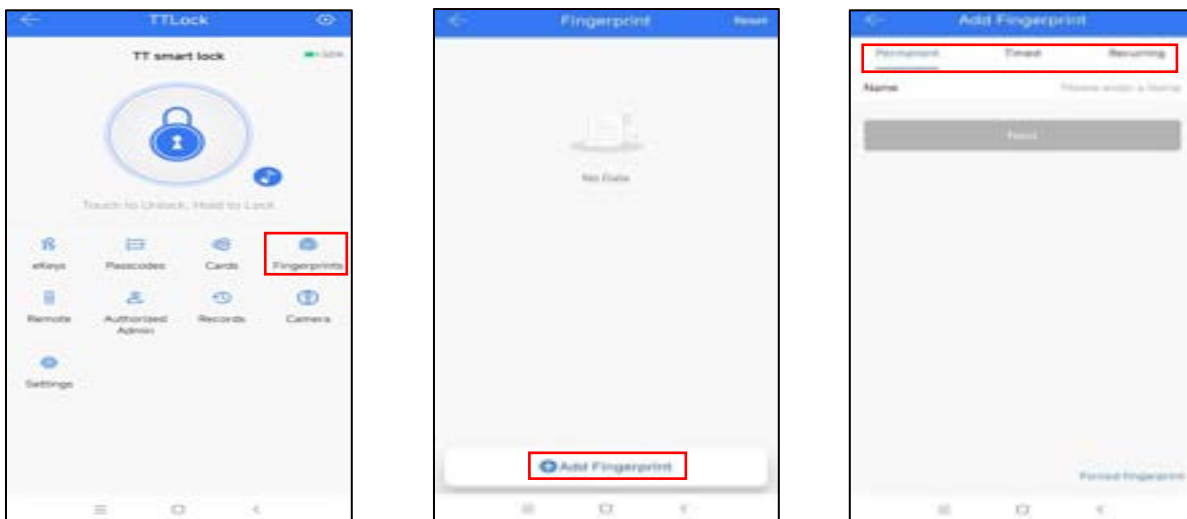





3.6.6. Remote unlock

Note: Must turn on" remote unlocking "

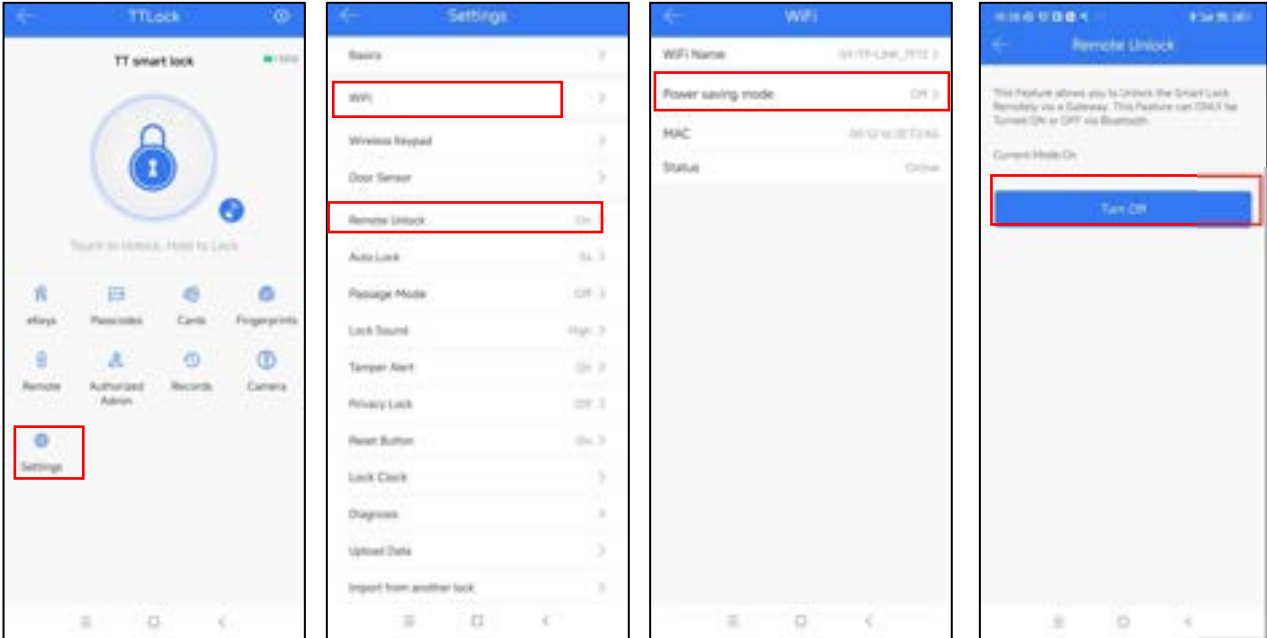
1. Turn on"remote unlock" in Settings, ensure that the lock is connected to WiFi and Turn off the "Power saving mode". Click"  " to remotely unlock.



2. Press "#" on the lock , the APP can receive remote unlock requests within a minute. Click"  " to enter the video intercom interface, you can talk to visitors, or click remote unlock.

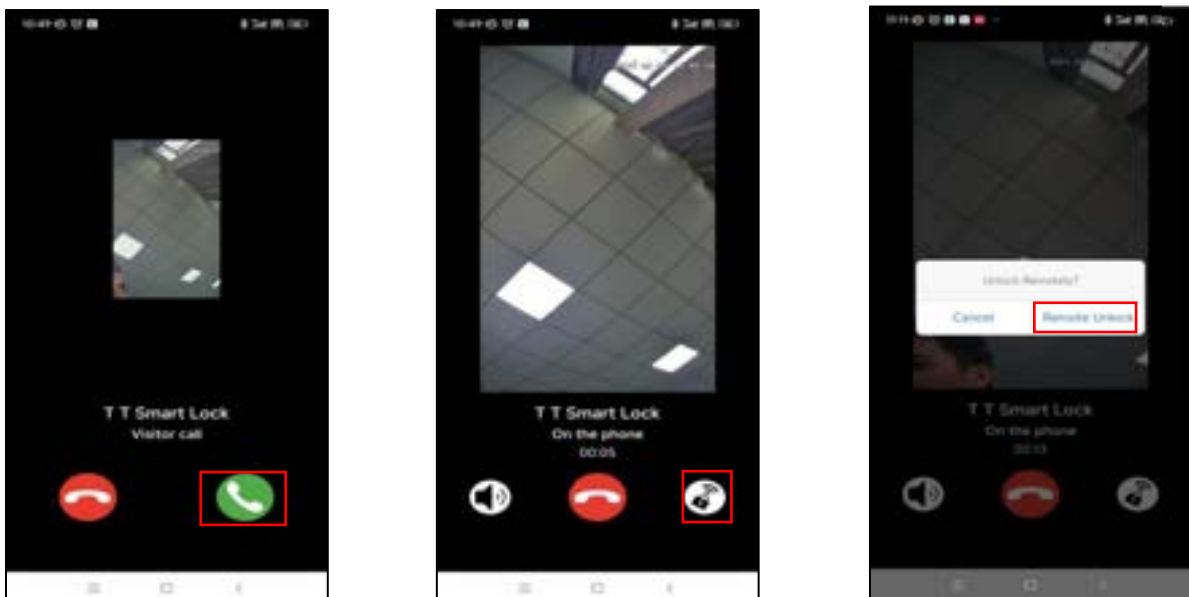



3.6.7. Camera

1. Requirements of use: The lock must be connected to WiFi, turn off the "Power saving mode" and turn on "remote unlock".

2. Operation: click "camera", The video intercom screen is displayed.

a) Click "🔇" for video intercom, You can also mute by clicking "🔊".

b) Click "📷" to Take a photo, Click "📹" to record, photos and videos are saved to the phone album.

c) Click "🔔", Alert information can be viewed by date.

d) Turn on "motion detection", if someone stays in front of the door for 10 seconds, the APP will receive a stay alarm, and the lock will upload the video to "warning message".

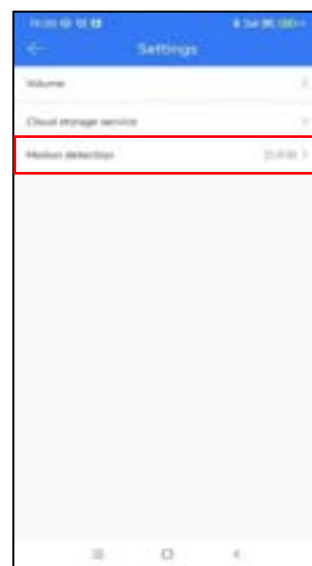
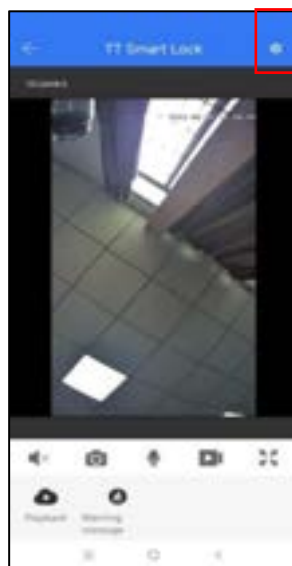
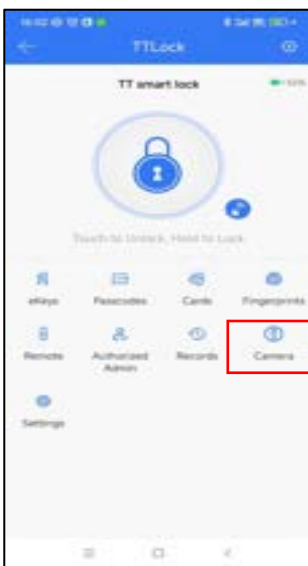

3.6.8. e-Key management

Click "🔑" The manager can delete ekey, reset ekey, send and adjust the ekey, meanwhile he can search the lock record.

3.6.9. Passcode management

Click "📄" All generated passcode can be viewed and managed in the passcode management module. This includes a passcode change, passcode deletion, passcode reset, and passcode unlock record.



3.7.1.Unlock records

Click "  "you can query your unlock record as shown in figure. (Refer to picture ④)

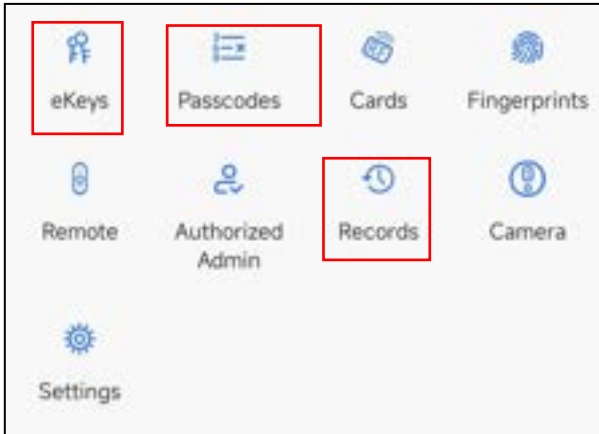

①

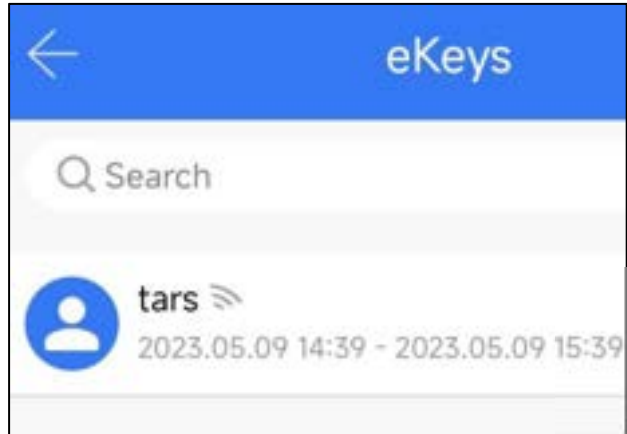

②

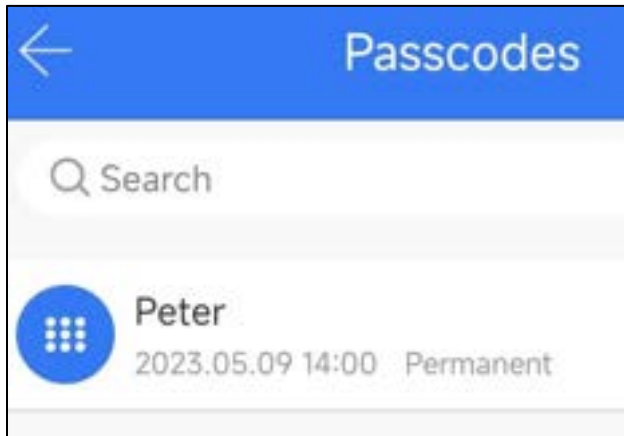

③

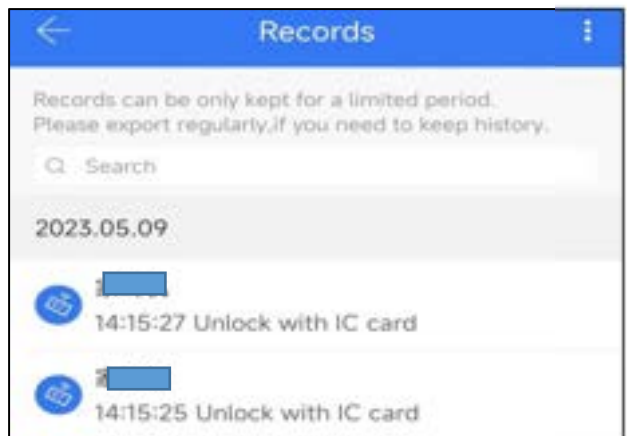

④

3.7.2.Setting

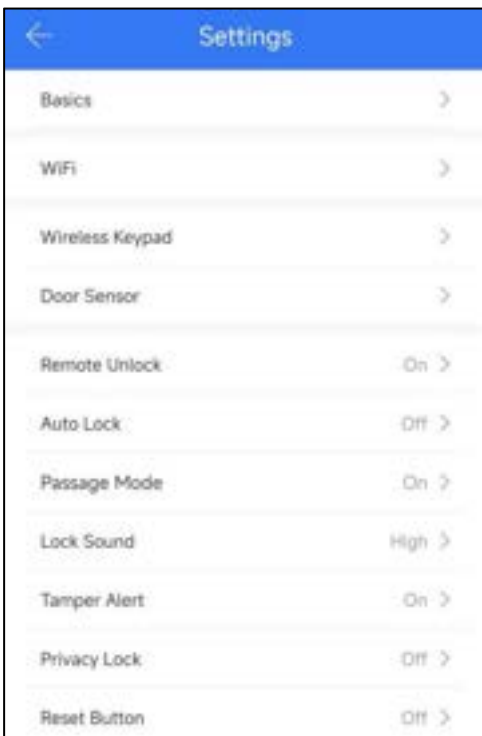

1. **Auto Lock** : Turn off auto locking after verifying unlock, the lock will always be in the "unlocked" position.

2. **Passage mode**: You can select a period of time to keep the lock in passage mode (unlocked).

3. **Privacy lock**: If the privacy lock is turned off the privacy button will become invalid and cannot function as a privacy lock.

4. **Reset button**: Turning off the reset button on the App means the lock can't be reset until it is turned back on.



4.FAQ

1) How to read operation records?	In the Records of the main interface.
2) Why can't I unlock it after open the passage mode	You need to perform an unlock verification in any method, then the passage mode will take effect.
3) What is the purpose of Auto Lock	You can set how long to lock after unlocking
4) After installation, touch sensing keyboard screen no response	<p>a) In this case, first check that the positive and negative electrodes of the battery have been installed correctly and whether the batteries have enough power.</p> <p>b) You need to remove the back panel of the lock and check to make sure the connecting wires where they join are securely connected. Also check wires are not damaged or squashed.</p>
5) Unable to register fingerprint	Check the fingers for dirt or wear, check the fingerprint head on the lock for dirt and oil stains, etc. Check to see if the fingerprint is working properly (Press to see if there is any response.
6) What is the reason why the smart lock consumes fast power?	<p>a) Connecting wire may not be jointed correctly.</p> <p>b) Short circuit.</p>
7) There is no response to pressing the handle on outside of the door lock, and there is unlock normally on inside the door, but the verification is normal, and the motor is normal.	It may be the triangle direction on the spindle hub is in the incorrect position and should be pointing down.
8) How many times consistently using the password will the keypad be locked? How long is it locked for?	Entering the wrong password more than 5 times in a row, the keypad is locked for 90 seconds.



Factory Warranty Card

Customer Name: _____

Customer Phone Number : _____

Purchase Date : _____

Product Name : _____

Product Model : _____

Note:

- ① Please keep this card so that you can use it when you need a warranty claim.
- ② We provide you with a one-year warranty from the date of purchase.